

Electrical Issues Due to Backup Lamps



Acadia backup lamp

Some 2017 Acadia (VIN N) and XT5 models may have several electrical issues, including a dead battery, an inoperative Stop/Start system, and instrument cluster and switch backlighting illumination conditions. These conditions may be due to the wrong bulbs installed in the backup lamps.

On 2017 models, incandescent bulbs are used in the backup lamps. In some vehicles, LED lamps may have been installed instead. The Body Control Module (BCM) evaluates the Reverse Lamp circuit to determine bulb outages by applying and monitoring a low voltage signal. Since LED lamps have different electrical properties than incandescent bulbs, the circuit does not operate as expected. The BCM is calibrated for incandescent bulbs and, as a result, may stay awake after the key is off if LED lamps are used, causing the BCM to continuously monitor the circuit, which can lead to multiple electrical conditions.

Check the backup lamps for the installation of the proper bulbs. If LED lamps are found, they should be replaced with incandescent bulbs.



Incandescent bulb

continued on page 2

CONTENTS

Electrical Issues Due to Backup Lamps . . .	1
Leaking Evaporator Core Seal	2
Incorrect Object Sensor Module Operation	3
Shifting Conditions Due to Undersized Spacer Plate	4
Correct Oil Filter Use on 1.4L and 1.8L Engines	4
Distorted or Blank Rear Vision Camera Screen	5



Customer Care and Aftersales

Leaking Evaporator Core Seal

Some 2016-2018 CT6 models may have decreased air flow at the instrument panel outer air vents while the vehicle is moving. The air conditioning evaporator core seal may not be sealing completely, allowing warm air to pass between the evaporator core and housing, which hits the evaporator temperature sensor and causes a false high reading. As a result, the compressor may continue to run and cause the evaporator to ice up.



Ice on evaporator core tube

If this condition is found, replace the seal around the evaporator core. The repair requires the removal of the instrument panel carrier and instrument panel tie bar. Refer to Bulletin #18-NA-052 for more information.



Evaporator core seal around the evaporator core

The CT6 uses an R-1234yf refrigerant system. To remove, recycle and install R-1234yf from/to a vehicle's refrigerant system, use the GE-50300 R-1234yf Air Conditioning Refrigerant Recovery/Recharge Cart or refrigerant/recovery/recharge equipment certified to meet the requirements of SAE J2843 and approved by the EPA.

After installation of the evaporator core seal, also perform the HVAC Actuator Learn procedure in the HVAC control module. Do not operate the climate controls while the HVAC control module is calibrating.

🙏 Thanks to Blake Streling

Electrical Issues Due to Backup Lamps

- continued from page 1

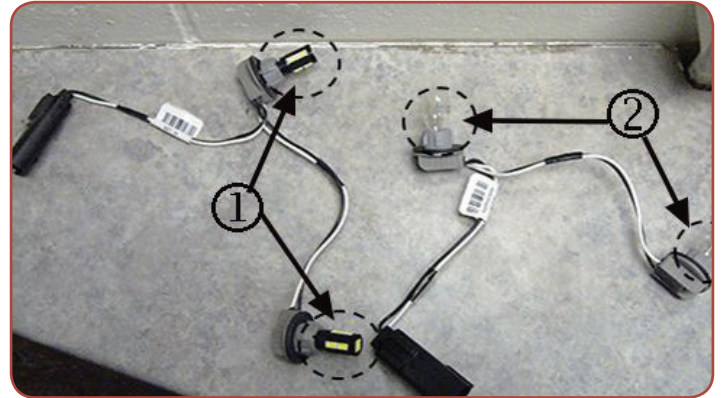

Check for LED lamps (1) and replace with incandescent bulbs (2).

On XT5 models, the backup lamp assembly is underneath the rear fascia.

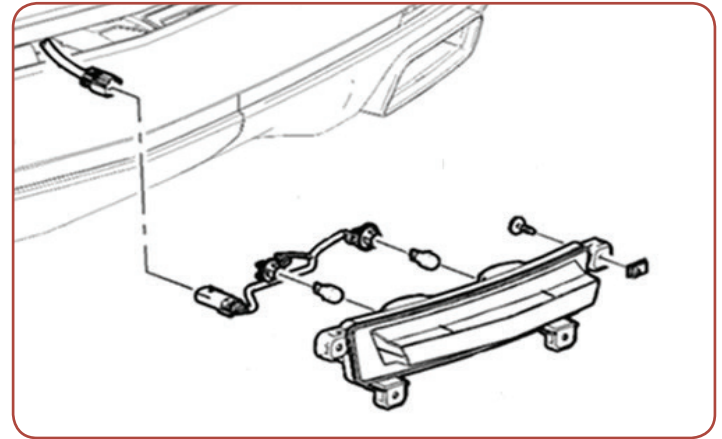

XT5 backup lamp

On Acadia models, the backup lamp is part of the rear signal lamp assembly.

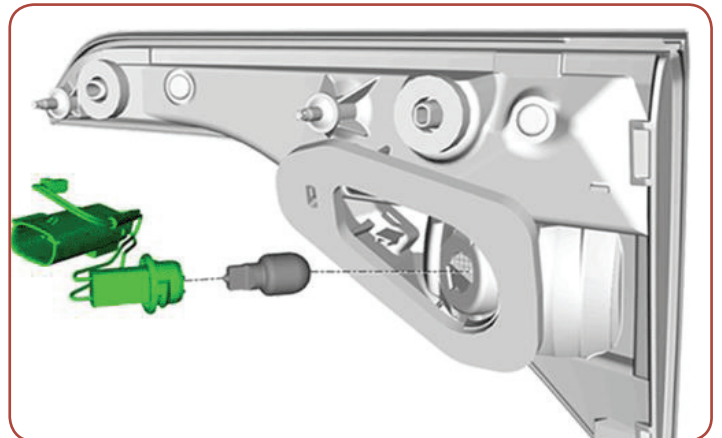

Acadia backup lamp

🙏 Thanks to Tom Burlingame

Incorrect Object Sensor Module Operation

Some 2018 Encore models equipped with Side Blind Zone Alert (RPO UFT, Side Active Safety–Obstacle Detection) may have a warning alert appear in the side mirror when there is not a vehicle present in the side blind zone area.



Warning alert in side rearview mirror

The incorrect notification may be caused by unwanted radar reflection being detected by the Side Object Sensor Module. Most radar reflections may be worse on the driver's side (left side) of the vehicle.

The Side Object Sensor Modules are located on each side of the vehicle behind the rear fascia. The sensors use radar to determine the presence of objects nearby. The Side Object Sensor Module – Left is the master that communicates on the vehicle serial data bus. There is a private serial data bus between the left and right sensors. The scan tool is able to communicate only with the left sensor. The sensors are unique and are not interchangeable from side to side. The Side Object Sensor Module – Right controls both side blind zone indicators located on the left and right side mirrors.

TIP: The Side Blind Zone Alert system can be turned on/off in the Settings menu on the infotainment system. Go to Settings > Vehicle > Collision/Detection Systems > Side Blind Zone Alert.

If the Side Blind Zone Alert system is not working properly, apply a piece of aluminum butyl tape to the bottom of the Side Object Sensor Module on the driver's side of the vehicle. The lower area of the module must be completely covered, including the wiring harness anchor point, to avoid unwanted radar reflections being detected.



Side Object Sensor Module

To apply the aluminum butyl tape, separate the wiring harness from the anchor point under the module and clean the bottom of the module and fascia using Acrysol or equivalent.

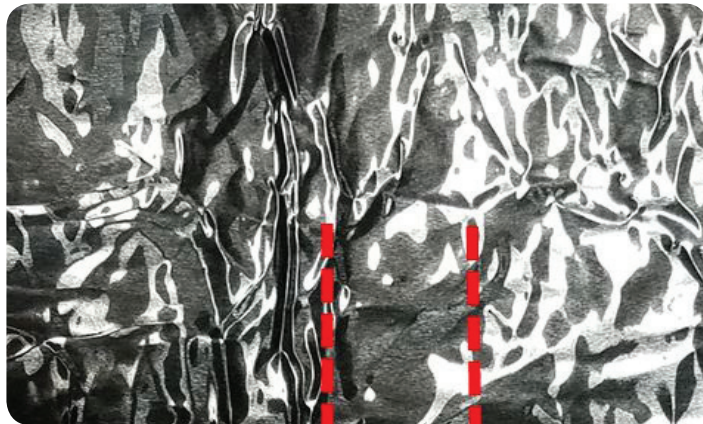

Aluminum butyl tape

The butyl tape should be 3.5 inches wide with a relief cut in the middle of the tape for the reflector mount. Pre-install the butyl tape to check for alignment to the reflector mount before peeling the backing off the tape.

Apply the butyl tape to the bottom of the module and fascia, making sure the area is completely covered, including the wiring harness anchor point.

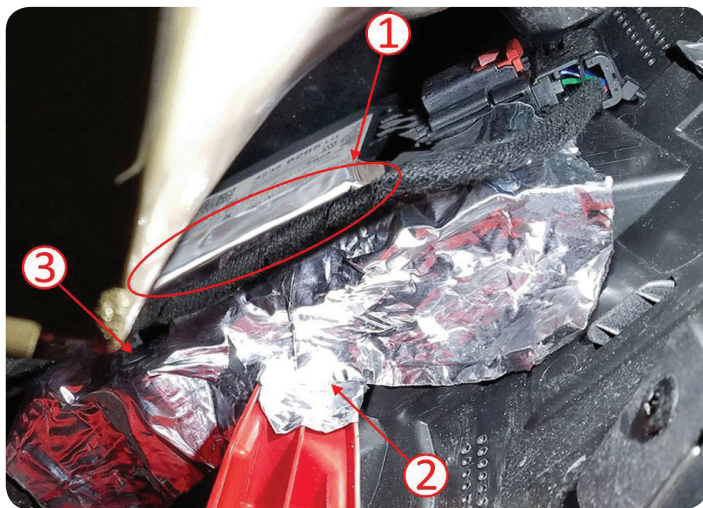

Tape applied to the module (#1), around the reflector mount (#2) and the wiring harness anchor point (#3).

After applying the butyl tape, check the operation of the Side Blind Zone Alert system. The system is designed to detect objects in an area approximately between 1.5 feet (0.5 m) and 6 feet (2 m) off the ground. The Side Blind Zone Alert monitors the blind spot area along the side the vehicle, approximately 11 feet (3.5 m) from the side of the vehicle, extending 16 feet (5 m) behind the mid-point of the vehicle. The Lane Change Alert detection zone extends to 230 feet (70 m) behind the vehicle.

🙏 Thanks to Frank Jakubiec

Shifting Conditions Due to Undersized Spacer Plate

Some 2018 Enclave, LaCrosse and Terrain models — from start of production to September 28, 2017 — may have several automatic transmission shifting conditions. These conditions apply to Enclave models equipped with the 9T65 automatic transmission (RPO M3W), LaCrosse models equipped with the 9T60 automatic transmission (RPO M3G), and Terrain models equipped with the 9T45 automatic transmission (RPO M3U) or 9T50 automatic transmission (RPO M3H).

During warm-up (transmission fluid below 32°F (0°C), a sharp deceleration may occur during the 1-2 upshift, as if the brakes were applied momentarily. The deceleration also may occur during a Manual 1 to Manual 2 upshift. During warm operation, a momentary neutral during the 2-4 upshift may occur, leaving the transmission stuck in 2nd gear. The Malfunction Indicator Lamp also may be illuminated.

In addition, DTC P2820 (Transmission Control Solenoid Valve 9 Stuck Off) may set in cold ambient temperatures after three consecutive failures during the same key cycle and the transmission may be limited to 1st gear operation.

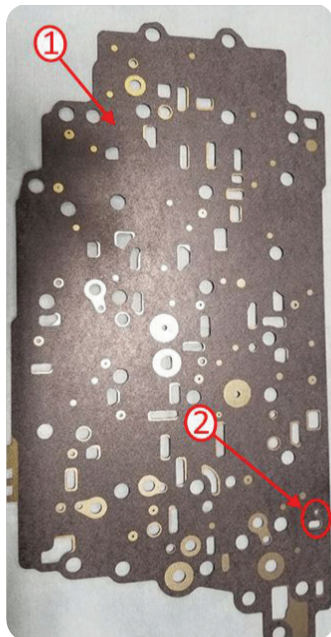

1. Spacer plate
2. Orifice

The shifting conditions may be caused by an undersized spacer plate, located between the valve body and the transmission case as an orifice. As a result, the clutch selector valve moves slowly to release the selectable one-way clutch, which causes a momentary transmission tie-up during the 1-2 upshift.

Inspect the valve body spacer plate orifice for proper size.

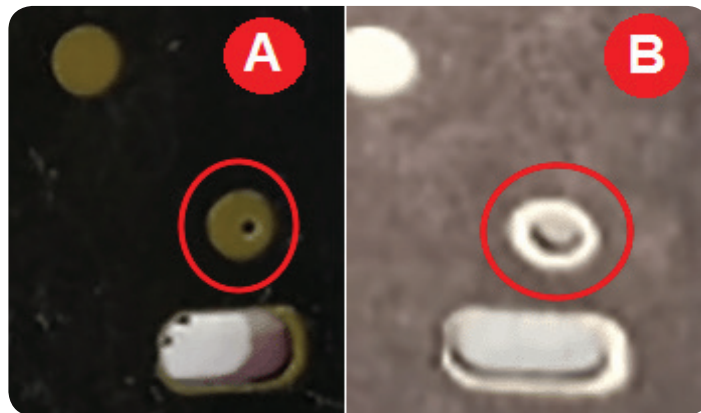

A. 0.5 mm orifice
B. 2.0 mm orifice

If the spacer plate orifice is 0.5 mm, replace the spacer plate. If the spacer plate orifice is 2.0 mm, continue with the diagnostics outlined in the appropriate Service Information.

🙏 Thanks to Mark Kevnick

Correct Oil Filter Use on 1.4L and 1.8L Engines

The 1.4L engine (RPO LUV) and 1.8L engine (RPO LWE) available in 2013-2018 Encore, Sonic, Trax; 2016 Cruze (VIN P); and 2013-2015 Cruze models use two different oil filters. Two suppliers provide the oil filter adapter housing assembly and each adapter housing assembly requires a different oil filter. It's critical to engine operation that the correct oil filter be used for the oil filter adapter housing application. The adapter insert also must be properly retained during an oil change.

In addition to using the VIN to identify the correct vehicle in the Electronic Parts Catalog (EPC), also look for the following characteristics of each specific oil filter.

Oil Filter PF2257G

ACDelco filter PF2257G identification:

1. No ribs
2. Felt-style gasket/seal
3. Supplier name: Hengst
4. Bypass valve in housing insert

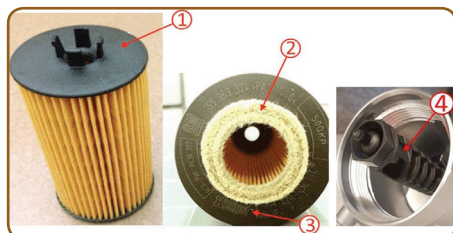

Oil filter housing identification for ACDelco filter PF2257G:

1. Black cap
2. Supplier name: Hengst
3. Smooth circumference of housing



Oil Filter PF2263G

ACDelco filter PF2263G identification:

1. Bypass valve in filter
2. 4 spacers/ribs
3. O-ring-style gasket/seal
4. Supplier name: UFI

Oil filter housing identification for ACDelco filter PF2263G:

1. Dark brown cap
2. Supplier name: UFI
3. Ribbed circumference of housing

For part number and usage, see Filter Kit, Oil in Group 01.836 in the EPC.

🙏 Thanks to Jeff Kropp

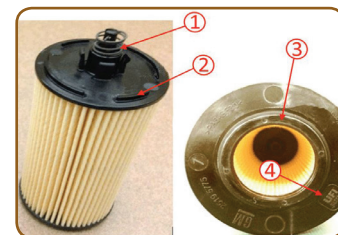

Distorted or Blank Rear Vision Camera Screen

When the Rear Vision Camera is active on some 2018 Sonic models, there may be a distorted, flickering, or rolling screen or the screen may be red/blue or black. In many cases, distortion or blank screen displays are due to signal interruption.

The Rear Vision Camera system operates when the transmission is placed into Reverse and 12V is applied to the reverse lamp control circuit by the Body Control Module (BCM). The rearview camera monitors the circuit and when 12V is seen, the rearview camera will activate. Video signal + and video signal - circuits carry the video image from the rearview camera to the infotainment system screen. The video signal circuits are shielded to prevent any interference that could lead to a degraded video signal resolution.

If the rearview camera displays a distorted or colored screen image, check for a pinched instrument panel wiring harness on the passenger-side of the vehicle between the instrument panel carrier and the A-pillar.

Instrument Panel Wiring Harness

Remove the instrument panel side trim cover to access the instrument panel wiring harness. Refer to M4 on the Instrument Panel Harness Routing grid in the Service Information.

If the wiring harness is pinched or shows signs of damage, repair the harness as needed.



Distorted red/blue screen image

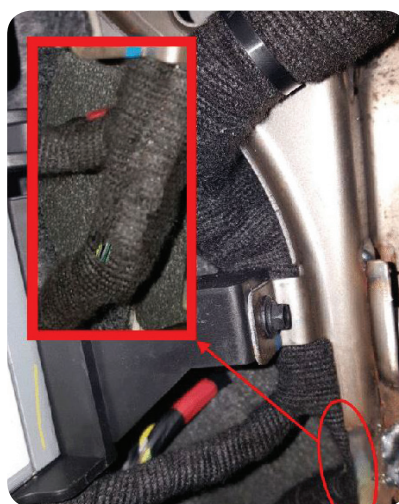

Check for a pinched instrument panel wiring harness.

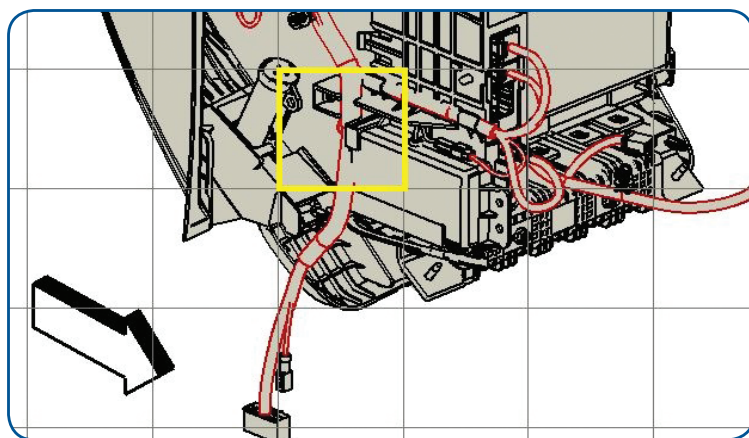

M4 on the Instrument Panel Harness Routing grid

GM TechLink is published for all GM retail technicians and service consultants to provide timely information to help increase knowledge about GM products and improve the performance of the service department.

Publisher:

John Meade
GM Customer Care and Aftersales

Editor:

Lisa G. Scott
GM Customer Care and Aftersales

Technical Editor:

Mark Spencer
mspencer@gpstrategies.com

Production Manager:

Marie Meredith

Creative Design:

5by5 Design LLC
dkelly@5by5dzn.com

Fax number:

1-248-729-4704

Write to:

TechLink
PO Box 500
Troy, MI 48007-0500

GM TechLink on the Web:

GM GlobalConnect

General Motors service tips are intended for use by professional technicians, not a "do-it-yourselfer." They are written to inform those technicians of conditions that may occur on some vehicles, or to provide information that could assist in the proper service of a vehicle. Properly trained technicians have the equipment, tools, safety instructions and know-how to do a job properly and safely. If a condition is described, do not assume that the information applies to your vehicle or that your vehicle will have that condition. See a General Motors dealer servicing your brand of General Motors vehicle for information on whether your vehicle may benefit from the information.

Inclusion in this publication is not necessarily an endorsement of the individual or the company.

Copyright© 2018 General Motors
All rights reserved.

Thanks to Frank Jakubiec