



GM TECHNICAL ASSISTANCE CENTER (TAC)

March Newsletter

March 01, 2022

“PROVIDE ADVANCED TECHNICAL REPAIR GUIDANCE,
RESULTING IN A SUPERIOR CUSTOMER EXPERIENCE”

The following are key TAC Tips as well as information from recent TAC cases to help resolve some known concerns or identify normal conditions on various GM models.

GENERAL

1) Intermittent Concerns

Please use **Bulletin #01-00-89-010N** Comeback Prevention Information and Using Customer Concern Verification Sheets (CCVS).

2) Field Product Reports

If any unusual conditions are noticed on a vehicle, please submit a Field Product Report using **Bulletin #02-00-89-002T** information for Dealers/Technicians on When and How to Submit a Field Product Report (FPR) (U.S. Dealers Only)

3) Service Information (SI) Feedback

For any issues with Service Information, please submit feedback using the feedback button”



” on the page with an error. This helps us all get better results from our searches.

4) Electrical Connection Concerns

In many areas, components and modules are being replaced and then poor grounds or wiring chafes, or even loose terminals, are found to be the root cause. Please be diligent in checking electrical connections and terminals prior to component replacement. Thanks to FSE input.

5) FSE Requests from Dealers

When working with the Technical Assistance Center and Field Service Engineers, it is important to utilize TAC when a vehicle comes in a second time for the same concern. This should be a normal course of action.

Prior to Field Service Engineer assistance, the dealer should:

- A. Have a clear understanding of the customer concern.
- B. Utilize the Customer Concern Verification Sheets (**Bulletin #01-00-89-010L**).
- C. Road test the vehicle with the customer/have customer demonstrate their concern.
- D. Contact TAC and perform a thorough search for bulletins.
- E. Check how far the case has been escalated through TAC.
- F. Accurately complete SI procedures and all TAC recommendations.
- G. Not omit any recommended diagnostic steps because it would take too long or did not feel it would work.
- H. Engage all available technical knowledge/experience.
- I. Have properly trained and experienced technicians involved.
- J. Have the shop foreman or service manager involved.

Knowing these things helps all of us that are trying to help our customers. In this way, TAC can help in retaining customers for life and ensure the future of our business.

ENGINE

1) #PIP5824A: 2021 HFV6 Gen2 Engine Misfire on AFM Cylinders 2 or 5

PI has been updated to include all MY 2021 and 2022 HFV6 Gen2 vehicles.

2) #PIP5838: Service Diesel Exhaust Fluid Tank Wiring Harness Pinout Change. Possible DTCs P20B9 and or P20C1

PI is now available along with a TechLink article highlighting the repair.

TRANSMISSION AND DRIVETRAIN

1) #PIP5842: Engine Stalling or Loud Rattle Noise Coming From the Engine Compartment with the Engine Running

PI is now available in SI and describes a condition that may be caused by broken stator dampener springs located inside the torque converter.

ELECTRICAL, CHASSIS AND TRIM

All Vehicles

1) Key Fob Learning Issues/Tips

If a vehicle comes to the dealership with at least one working key fob (RKE transmitter), and the customer requests to have another key fob added or replaced, exit the learn procedure if issues arise when learning the new key fob. Do NOT perform any learn procedures that will delete the original working key fob. The new key fob should be tested with the EL-52545 TPMS and RF Tool. Make sure there is not a VIN learned to the new fob, that the frequency matches the vehicle, and that the correct part number of the key fob has been verified by the parts department.

If the new key fob is correct, remove the battery from the original/known good working key fob. Place the key fob in the pocket in the vehicle and, with all other key fobs at least 10 feet from the vehicle, determine if the vehicle will start. If the vehicle starts, this verifies the fob is being placed in the correct fob pocket location and that the IMMO coil is working. If the vehicle will not start with the fob in the pocket, check the owner's manual to verify the location of the key fob pocket. Also check the installation of the pocket IMMO antenna and the electrical connection.

If diagnosis does not lead to a repair, contact TAC prior to trying the delete all keys procedure. Deleting the learned key fob(s) rarely corrects the concern and, once the key fob(s) are deleted, the vehicle will not start and may become stuck in its current location until a key fob can be learned to the vehicle. In order to learn the key fob back to the vehicle, the original, underlying concern will need to be corrected. If the original keys are not deleted, at least the vehicle can be started and driven until the root cause is determined.

Performance Cars

1) Exhaust Valve Actuators – Know the Type and Purpose

- A. The PEV (Passive Exhaust Valve) is a purely mechanical valve. There are not any electronics involved whatsoever. No wires, no controls. It is a butterfly valve located inside the exhaust pipe that rotates from a small coil spring. The PEC is actuated by the pressure of the exhaust gasses that flow through the pipe. These valves are used in certain applications on the Camaro still.
- B. The Vacuum Operated Exhaust Valve another mechanical exhaust valve that does not have any electronics. A solenoid is activated that allows vacuum to be applied to the normally open valves. Once vacuum is applied, the valve closes. This type of valve was used on 5th gen Camaros (2010-2015). It was fairly simple, as there are no learn procedures. It is just open or closed, meaning it is either working or not working. These valves are not used on any current product.
- C. The Electronic Exhaust Valve Actuator is the most common valve used on vehicles today. It is an electronically-controlled exhaust valve that is similar to a really heavy-duty HVAC actuator. It has a certain range of motion, limits, learns, and, depending on where it's located in the vehicle, is capable of setting several DTCs as well. The purpose of these valves is to lessen the ability of the customer to hear the transitions of the engine going in and out of V4/V8 modes or to increase the "power" sound from the engine. For these reasons, it is imperative to list if the concern is dealing with a front or rear valve, as well as left or right hand.

2) Bulletin #22-NA-019: Malfunction Indicator Lamp (MIL) Illuminated with DTC P2251 and/or DTC P2254 Set

New bulletin for some 2022 MY Corvettes for an ECM reprogram related to an O2 system issue.

3) Bulletin #22-NA-026: Information on Brake Pulsation, Noise and/or Visible Pitting Condition to Brake Rotor Surface

New bulletin for 2021-2022 Corvettes covering a variety of brake issues related to parking the car for an extended amount of time.

4) Bulletin #21-NA-290: Wrinkle or Bubble in Stripe or Hood Wrap forming Around Outer Edges of Hood Air Scoop

New bulletin for 2019+ Camaros with either a set of hood stripes or a hood wrap. The issue is that the decals seem to be bubbling up around the radius of the hood vent or heat extractors. The heat extractor modification should prevent the stripes/hood wraps from wrinkling in the future.

Cars and Crossovers

- 1) **Bulletin #18-NA-069: Poor Engine Performance in Extremely Cold Weather Conditions for LFV Engines, Charge Air Cooler Icing - Malfunction Indicator Lamp (MIL) Illuminated - DTC P0299, P0236, P2227 and/or P00C7 Set**

Updated bulletin includes provisions on modifying the grill cover to accommodate the front license plate bracket for 2016-2022 Malibu models.

Trucks

- 1) **Medium-Duty Truck Tire Adapters**

The following adapters are needed to service large bore tires.

Balancer

20-2977-2 Large Bore 8 Stud Kit – 8.7-inch bore for use with medium-duty trucks with 19.5-inch rims.

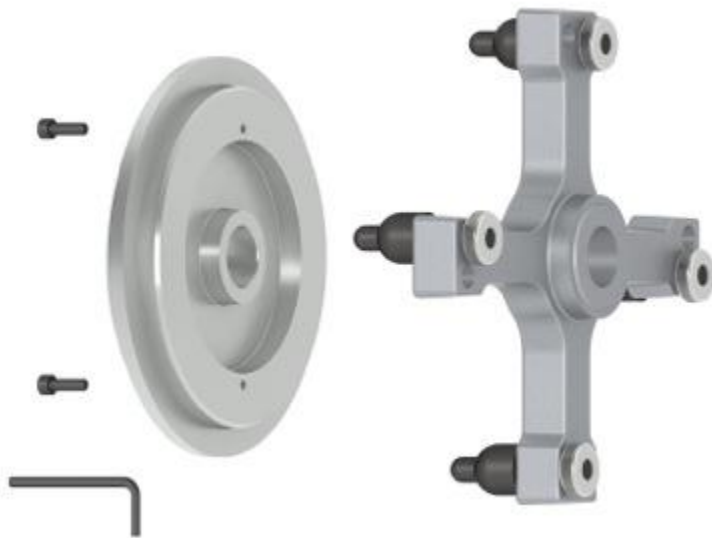

Tire Changers

20-2964-1 Kit-Large Bore, Dual Wheel – Expands clamping capability into 16-inch, 17-inch, 19.5-inch and more dual-wheel applications. Suitable for Revolution Tire Changer only.



20-3160-1 Thick Bead Kit for Revolution – Includes thick bead hook and reverse wheel adaptor. Suitable for load range G, H, J tires. Suitable for all generations of Revolution Tire Changers running 1.4 or greater software.



INFOTAINMENT AND ONSTAR

1) Contacting TAC for Infotainment Issues

When contacting TAC for assistance with an infotainment issue, please provide the vehicle's current Radio Software Version. The software version will greatly assist the Infotainment team in determining the best recommendations for the issue.

HYBRID AND EV

1) All EVs – Bleeding Air After Opening a Cooling System

When replacing a battery pack, remember to bleed the cooling system. Also run the coolant pump after opening the cooling system using GDS2 to help purge out the remaining air. This is documented in the SI procedure.

2) Bulletin #22-NA-024: Vibration, Hum or Drone Noise Heard from Front of Vehicle While Driving at Highway Speeds

New Bulletin for Bolt EV.

3) Bulletin #21-NA-239: Unable to Charge Message in Driver Information Center (DIC), No Start Due to Charge Cord Ground Fault

New Bulletin for Bolt EV and EUV.

DCM AND TAC CASES

1) Opening TAC Cases in DCM

When opening a TAC case that includes several DTCs, submit a session log into the case per the latest version of #PIP5632 to ensure that all codes are included. In addition, on VIP vehicles, include the Network Communication Event Results and Network Communication Status data lists.

2) Closing TAC Cases

When finishing a vehicle with a TAC case, please submit a closing with as much information as possible. By doing so, we can all help each other share as much information as possible to help take care of our customers efficiently. Remember: **ONE TEAM.**

When submitting a case closing, please only submit cases when the vehicle has actually been repaired.

If the vehicle is no longer at the dealership or is waiting for parts, the case can be closed unlinked, which becomes unsearchable so that incomplete information is not shared with others.

If you already have a recent TAC case on a vehicle and you find that it is closed, and you would like to update it for the same issue, please call TAC and we can reopen the case instead of starting a new case. Reopening the case will help ensure that all relevant information will be in one place for the consultant to best assist with the concern.